

Specification for Microphone	Page	2/9
	Revision No.	1.0
	Drawing No.	KIC10038
Model No. : 10038 MIC module		

CONTENTS

1. Scope
1.范围
2. General
2.概要
3. Electrical and Acoustic Characteristics.
3.电声参数
4. Mechanical characteristics and environmental test
4.机械特性和环境试验
5. Circuit Diagram & Response curve
5.测试图和曲线图
- 6.1 Dimensions
6.1尺寸图
- 6.2 Print
6.2表面印字要求
7. Packing
7.包装
8. Revision
8.履历表

Specification for Microphone	Page	3/9
	Revision No.	1.0
	Drawing No.	KIC10038

Model No. : 10038 MIC module

1. Scope 范围

This specification applies electret condenser microphone.

此规格书适用于电容式麦克风.

2. General 概要

- 2.1 Out-size : 20X14.2 mm
 2.1.外尺寸 : 20X14.2 mm
 2.2 Length : 150 mm
 2.2. 长度 : 150 mm
 2.3 Weight : ≤8 g
 2.3 重量 : ≤8 g
 2.4 Operating Temperature range: '-40 ~ +85°C without loss of function
 2.4 工作温度: -40 ~ +85°C
 2.5 Store Temperature range: '-40 ~ +85°C without loss of function
 2.5 储存温度: -40 ~ +85°C

3. Electrical and Acoustic Characteristics. 电声参数

Test condition : 15 ~ 35°C, 45 ~ 85%RH, 860 ~ 1060mbar

测试条件 : 15 ~ 35°C, 45 ~ 85%RH, 860 ~ 1060mbar

No	Items	Symbol	Unit	Specification	Condition
1	Directivity 指向性			unidirectional 单指向性	
2	Sensitivity 灵敏度	S	dB	-3.5±2dB	0dB=1V/Pa,1KHz
3	StandardOperationVoltage 标准操作电压	Vs	V.D.C	9±10%	340*2 OHM
4	Max. Current Consumption 最大耗电流	I _{ss}	mA	<15	
5	distortion 失真度			≤1.5%	at 1KHz,94DB SPL,0.5m
6	Material 材质			Compliance with RoHS	
7					
8					
9					

We use "Pascal (Pa)" indication of sensitivity as per the recommendation of I.E.C (International Electro technical Commission).The Sensitivity of "Pa" will increase 20dB comparing with "ubar" indication.

Example : -60dB(0dB=1v/ubar)=-40dB(1v/Pa)

依I.E.C.(国际电子协会) 建议, 以"Pa"为灵敏度标示单位比"ubar"灵敏度标示单位增加20dB

例如;-60dB(0dB=1V/ubar)=-40dB(1V/Pa)

Specification for Microphone	Page	4/9
	Revision No.	1.0
	Drawing No.	KIC10038

Model No. : 10038 MIC module

4.1 Mechanical Characteristics 机械特性

No.	Item	Test Condition	Evaluation standard
1	Vibration 振动 试验	To be no interference in operation after vibrations. 10Hz to 50Hz for 1 minrte full amplitude 1.52mm , for 2 hours at three axes 1分钟频率变化从10Hz到50Hz,振幅在1.52mm,在三个方向测试振动2小时,产品应不受影响	After any tests,the sensitivity to be within $\pm 3\text{dB}$ 测试其灵敏度须与原测试值的差异不超过 $\pm 3\text{dB}$
2	Drop test 跌落测试	To be no interference in operation after dropped to concrete floor each one time from 1meterheight at three directions in state of packing 以正规包装的三个方向从1米高处自由落到混凝土地面时 产品应不受影响	

4.2 Environmental test 环境试验

No.	Item	Test Condition	Evaluation standard
1	High Temperature Test 高温测试	After being placed in a chamber at $+85\pm 2^\circ\text{C}$ for 1000 hours 置于 $+85\pm 2^\circ\text{C}$ 环境中1000小时	After any tests,the sensitivity to be within $\pm 3\text{dB}$ of initial sensitivity after 3H of conditioning at $+25^\circ\text{C}$ 经测试后麦克风,须静置于 $+25^\circ\text{C}$ (室温)环境中3小时后,测试其灵敏度须与原测试值的差异不超过 $\pm 3\text{dB}$
2	Low Temperature Test 低温试验	After being placed in a chamber at $-40\pm 2^\circ\text{C}$ for 1000 hours 置于 $-40\pm 2^\circ\text{C}$ 环境中1000小时	
3	Humidity Test 相对湿度试验	After being placed in a chamber at $+45^\circ\text{C}$ and 90-95% relative humidity for 96 hours 置于 $+45^\circ\text{C}$,相对湿度90-95%环境中96小时	
4	Temperature Impact Test 温度冲击试验	After being placed in a chamber at $-40\pm 3^\circ\text{C}$ for 30 minutes,and then $85\pm 3^\circ\text{C}$ for 30 minutes each 10 times 在 $-40\pm 3^\circ\text{C}$ 环境中放置30分钟,然后在 $85\pm 3^\circ\text{C}$ 环境中放置30分钟,这样循环10次	
5	Temperature Cycles Test 温度循环试验	After being placed in a chamber at $-40\pm 2^\circ\text{C}$ for 2H,the temperature rises from $-40\pm 2^\circ\text{C}$ to 25°C gradually,it takes 1 hour.Then being placed in a chamber at 25°C for 2H,temperature rises from 25°C to $85\pm 2^\circ\text{C}$ gradually,it takes 1 hour,then being placed in a chamber at $85\pm 2^\circ\text{C}$ for 2H,the temperature rises from $85\pm 2^\circ\text{C}$ to 25°C gradually,it takes 1 hour.Then being placed in a chamber at 25°C for 2H,the temperature rises from $25\pm 2^\circ\text{C}$ to -40°C gradually. Above cycles 10 times 先在 $-40\pm 2^\circ\text{C}$ 的试验箱内放置2H,再经过1H温度上升到室温($+25^\circ\text{C}$)后在此环境中放置2H,再经过1H温度上升到 $85\pm 2^\circ\text{C}$ 后在此环境中放置2H,再经过1H温度下降到室温($+25^\circ\text{C}$)在此环境中放置2H,再	

Standard Test Condition: a)Temperature: $+15 \sim +35^\circ\text{C}$ b)Humidity:45 ~ 75% c)Pressure:86 ~ 106kPa

标准测试条件: a)环境温度: $+15 \sim +35^\circ\text{C}$ b)相对湿度:45 ~ 75% c)大气压力:86 ~ 106kPa

Judgement Test Condition: a) Temperature: $(20\pm 2)^\circ\text{C}$ b) Humidity:60 ~ 70% c) Pressure:86 ~ 106kPa

判定测试条件: a) 环境温度: $(20\pm 2)^\circ\text{C}$ b)相对湿度: 60 ~ 70% c)大气压力: 86 ~ 106kPa

5. Circuit Diagram & Response curve

测试

图和曲线图

5.1 Circuit Diagram 测试图

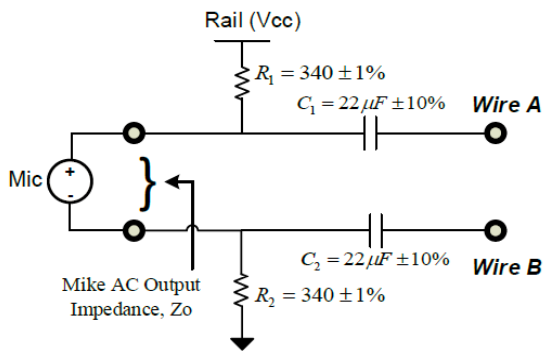

测量线路

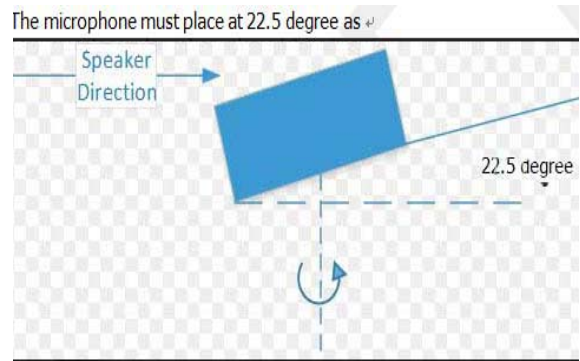

测量图示

5.2 Response curve 曲线图

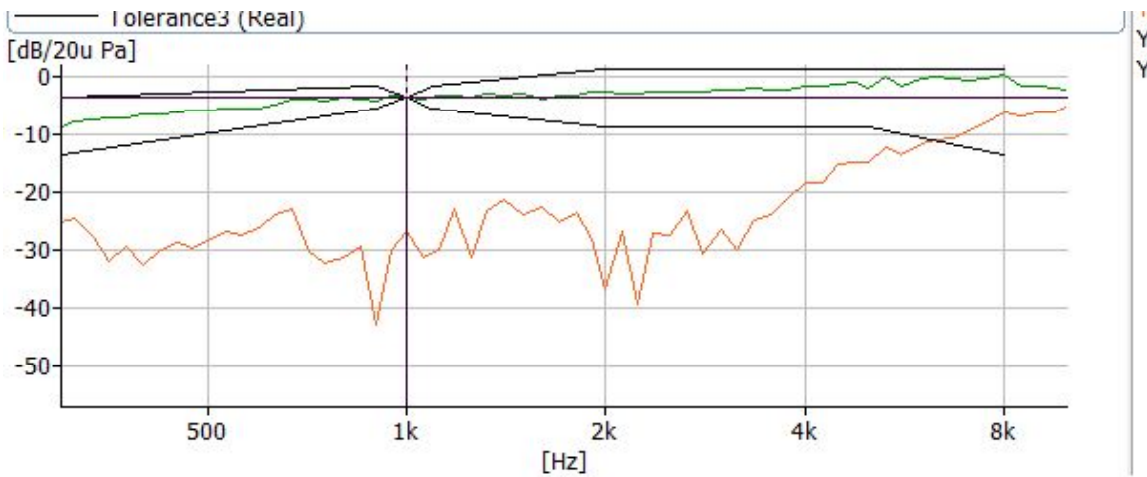

Frequency (Hz)	Lower Tolerance (dB)	Upper Tolerance (dB)
100	-∞	4
300	-10	5
800	-2	2
1K	0	0
1.25K	-2	2
2K	-5	5
5K	-5	5
10K	-10	5

Specification for Microphone

Page

6/9

Revision No.

1.0

Model No. : 10038 MIC module

Drawing No.

KIC10038

6.1 Dimensions 尺寸图

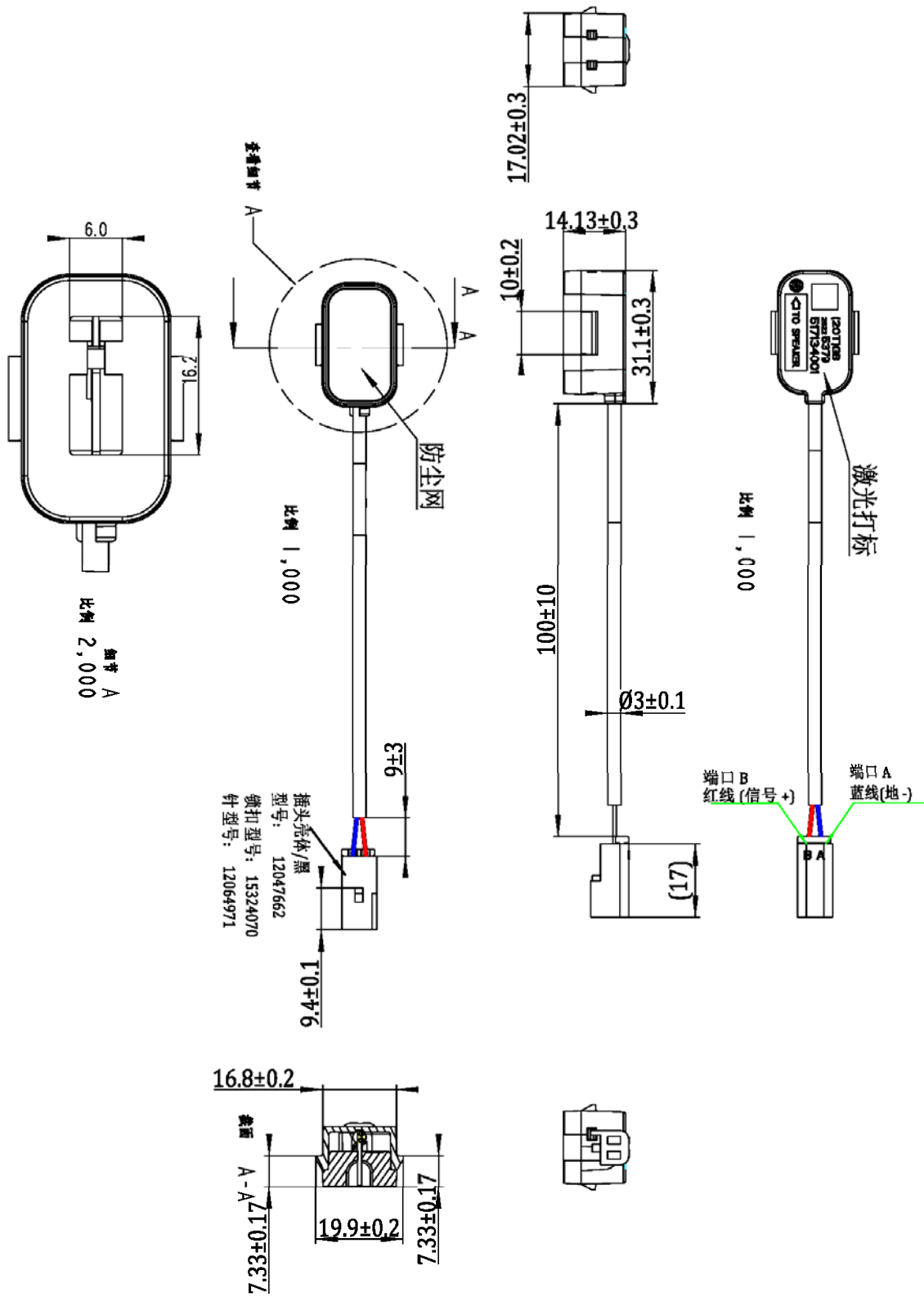

THIRD ANGLE PROJECTION



Specification for Microphone

Page

7/9

Revision No.

1.0

Model No. : 10038 MIC module

Drawing No.

KIC10038

6.2.print 表面印字要求



0=0	8=8	16=G	24=Q	32=Y
1=1	9=9	17=H	25=R	33=Z
2=2	10=A	18=J	26=S	
3=3	11=B	19=K	27=T	
4=4	12=C	20=L	28=U	
5=5	13=D	21=M	29=V	
6=6	14=E	22=N	30=W	
7=7	15=F	23=P	31=X	

生产序号34进制转换表

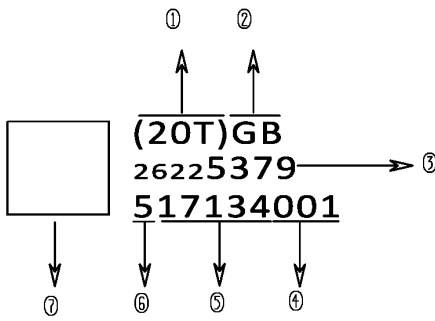

- ①. 最多 19个数
- ②. 麦克风编号
- ③. GM产品型号
- ④. 产品生产序号(34进制, 见上图)
- ⑤. 日期编码, 表示17年第134天
- ⑥. 供应商编码
- ⑦. 二维码中内容: 20TGB5379517134001



Specification for Microphone Model No. : 10038 MIC module	Page	8/9
	Revision No.	1.0
	Drawing No.	KIC10038

7.Packing 售后包装



1 pcs/内盒



1 pcs/内盒+气泡袋
贴标贴+合格证



10 pcs /外箱
箱体尺寸 : 25x20x18.5cm
贴标贴+合格证



